

# **AFS-Europe**

Complete fiber optic  
testing solutions

[www.afs-europe.com](http://www.afs-europe.com)

***TBX SERIES MANUAL***

### Tool Box Contents & “Check List”

Part name	Check Off
Tool Box Manual	
Safety Glasses	
Tubing Cutter	
Needle Nose Pliers	
Kevlar® Scissors	
Rotary Cable Stripper	
Fiber Optic Stripper	
Buffer Tube Stripper	
Crimp Tool	
Sapphire Scribe	
Polishing Plate Lexan®	
Polishing Pad Neoprene	
Tweezers	
Polishing Puck	
Continuity Tester	
Inspection Microscope	
Fiber Optic Power Meter	
Fiber Optic Light Source	

## Fiber Optic Installation Safety

When one speaks of safety in fiber optic installation, the first image that comes to most people's minds is a laser burning holes in metal. While these images may be real for their applications, they have no relevance to fiber optics. Optical sources used in fiber optics are of much lower power levels and are not focused into a time spot like these applications.

In fact, most datacommunications links use LEDs of very low power levels, and even the lasers in most fiber optic installations are of relatively low power. The light that exits an optical fiber is also spreading out in a cone, so the farther away from the end of the fiber you are, the lower the amount of power striking a given sized spot. Furthermore, the light is of a wavelength that cannot penetrate your eye because of the absorption of the water in your eyeball at those wavelengths. In order to do any damage, the end of the fiber would have to be held against your eyeball for hours! A complete safety study and report is in ANSI Z136.2.

### **Bare Fiber Safety**

Fiber optics installation, however, is not without risks. As part of the termination and splicing process, you will be continually exposed to small scraps of bare fiber cleaved off the ends of the fibers being terminated or spliced. These scraps are very dangerous. If they get into your eyes, they are very hard to flush out. Always wear safety glasses when working with bare fibers. A pair of safety glasses is included in the kit. Use them, keep them clean, and protect them from damage like any other tool.

The cleaved ends are extremely sharp and can easily penetrate your skin! Be careful to not stick the broken ends into your fingers, since they invariably break off and are very hard to find and remove. Most times, you have to wait for them to infect and painfully work themselves out. A pair of tweezers are included in the kit for removing splinters. Carefully pull the glass splinters out before they have a chance to break off and become lodged in the skin.

Avoid these painful accidents by exercising a little caution. Dispose of all scraps properly. Keep a piece of double stick tape on the bench to stick them to or put them in a properly marked paper cup or other container to dispose of later. Do not drop them on the floor where they will stick in carpets or shoes and be carried elsewhere. Do not eat anywhere near the work area.

***Note: Fiber optic installation often involves working near power cables. Whenever you are near these cables, there is danger of electrical shock. If you are not familiar with electrical safety, please take a training course on the National Electrical Code (NEC), which will also educate you on Section 800 which covers fiber optic cabling.***

### **Other Considerations for Safety**

Fiber optic splicing and termination use various chemical cleaners and adhesives as part of the processes. Normal handling procedures for these substances should be observed. Even simple isopropyl alcohol, used as a cleaner, is flammable and should be handled carefully. Note fusion splicers use an electric arc to make splices, so care must be taken to insure no flammable gasses are present in the space where fusion splicing is done.

Smoking should also not be allowed around fiber optic work. The ashes from smoking contribute to the dirt problems with fibers, in addition to the possible presence of combustible substances.

### **Fiber Optic Installation Safety Rules**

1. Keep all food and beverages out of the work area. If fiber particles are ingested they can cause internal hemorrhaging
2. Wear disposable aprons to minimize fiber particles on your clothing. Fiber particles on your clothing can later get into food, drinks, and/or be ingested by other means.
3. Always wear safety glasses with side shields. Treat fiber optic splinters the same as you would treat glass splinters.
4. Never look directly into the end of fiber cables until you are positive that there is no light source at the other end. Use a fiber optic power meter to make certain the fiber is dark. When using an optical tracer or continuity checker, look at the fiber from an angle at least 6 inches away from your eye to determine if the visible light is present..
5. Only work in well-ventilated areas.
6. Contact lens wearers must not handle their lenses until they have thoroughly washed their hands.
7. Do not touch your eyes while working with fiber optic systems until your hands have been thoroughly washed.
8. Keep all combustible materials safely away from the curing ovens.
9. Put all cut fiber pieces in a properly marked container for disposal.
10. Thoroughly clean your work area when you are done.
11. Do not smoke while working with fiber optic systems.

## Armored Cable Cutters

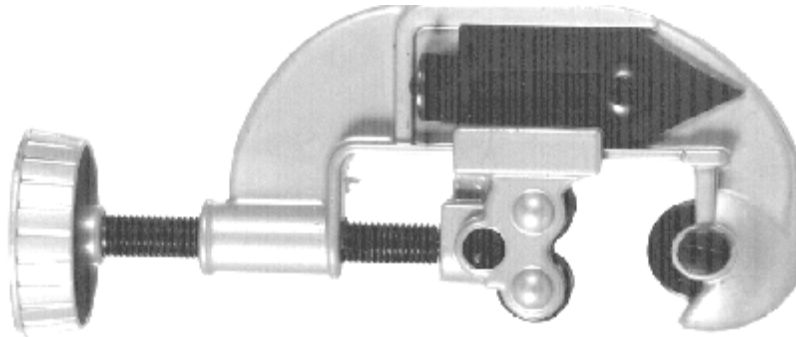

This tubing cutter can be used with 1/8" to 1 1/8" outside diameter armored cables. It features an alloy steel cutting wheel and two grooved rollers for cutting through both outside jacket and armor.

- Open the jaws of the tool and rest the tubing or cable on the two rollers.
- Tighten the rollers into the cable until the jacket lightly touches the cutting wheel.
- To make the cut, rotate the tool around the cable. Make sure the cable is on the two rollers squarely to avoid making a spiraling cut. After each rotation tighten the cutter a 1/2 turn. Do not try to cut through the jacket too quickly.
- Cut into the cable until the shoulder of the cutting wheel touches the cable jacket. This should complete the cut. Tightening further will crush the cable.

### **Needle Nose Pliers**

These extra long needle nose pliers are excellent at getting into hard to reach places. They are spring opened for ease of use and have a comfortable padded grip.

Use these pliers when accessing and pulling pull cords, or ripcords. Grab the pull cord firmly with the pliers; roll the cord around the jaws, and pull axially to slit the cable open. Do not pull at 90 degrees to the cable. This will break the pull cord.

### **Kevlar® Scissors**



These durable super-sharpened cutters were specially selected for making repeated cuts of the tough Kevlar® fibers used in fiber optic cable. They are made from hard stainless steel to stand up to repeated use on Kevlar® fibers. These scissors should be used only for cutting aramid yarn (Kevlar®).

Bunch all the aramid yarn together into a rope and cut all the fibers at once. The cutters should cut through in 1 to 2 snips.

**Note:** Do not use these scissors to cut anything but the Kevlar fibers! If they dull from cutting other things, they will not cut Kevlar cleanly!

**Note - do not use for cutting Epoxy packets! The epoxy will ruin the cutting edge of the scissors!**

## Round Cable Slitting and Ringing Tool

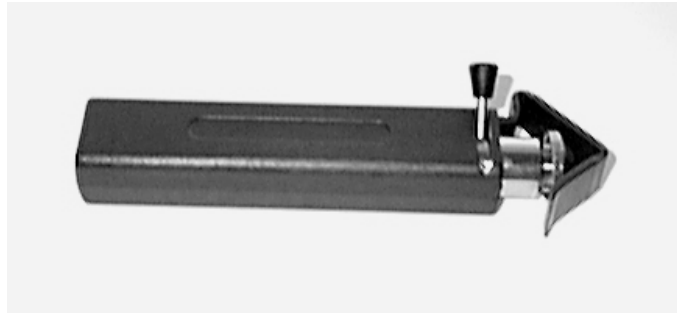

The Cable Slitting and Ringing tool can be used on cable with an outside diameter of up to 2.75in. The blade is adjustable for jacket thickness' up to 0.187in.. The blade can be turned 90 degrees for an axial cut, left in its normal position set for a round cut or changed to a 'in between' angle for a spiral cut. A spare blade is stored in the handle.

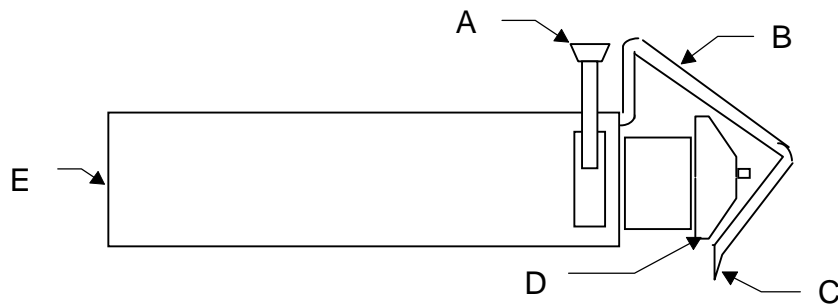

- A) This lever controls the blade direction. Push and hold to make an axial or spiral cut. If left in place, the blade will cut around the cable.
- B) The bar forces the cable into the cutter. Push the cable retention bar out to insert the cable into the tool. Once the cable is inserted, this bar will provide the force to slit most cables.
- C) After slitting the cable jacket, place the wedge on the head of the cable retention bar into the slit to enlarge the opening.
- D) Adjust the depth of the blade by rotating the knurled adjustment cone. When the cone is turned clockwise, to go in, more blade is exposed. When the cone is turned counter clockwise, to go out, less blade is exposed. Measure the blade against the thickness of the cable jacket. (Make a trial cut near the end of the cable to check the blade height.)
- E) The spare blade is stored in the base of the handle. With a small screw-driver, slide the bar to the opposite end of the slot in the handle to release the spare blade.

## Fiber Optic Stripper

Fiber Optic Stripper is used for both jacket and buffer removal without any scratching or nicking of the optical fiber. The stripper has two stripping notches. The larger notch is designed for stripping 2-3 mm cable jackets and the smaller notch will strip 250 micron buffer coating from 125-micron optical fiber. The stripping hole is precision drilled to 0.005" (0.14mm) in diameter. All cutting surfaces are specifically formed, hardened, tempered and ground to assure proper buffer removal.

### Stripping Cable

Use the larger (first) notch in the stripper to strip the jacket from cables. **DO NOT STRIP LIKE COPPER WIRE STRIPPING!**

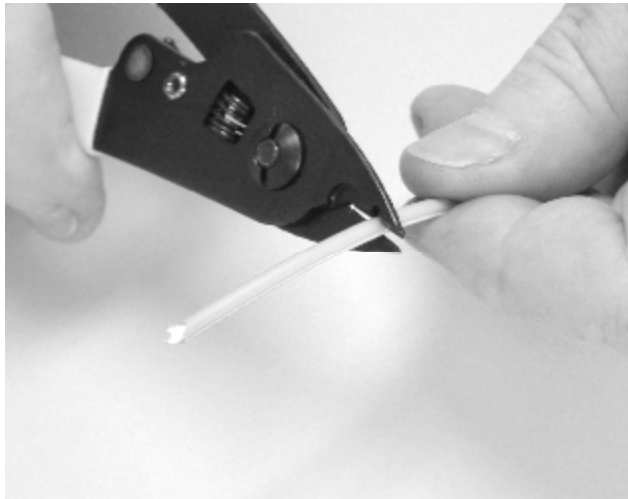

Place the cable in the large notch and close the stripper firmly to sever the cable jacket. Grasp the jacket with two fingers, rotate to make sure it is severed completely and pull off gently.



## Stripping Fiber

Use the smaller inner notch on the stripper to strip off the buffer coating of the fiber. Always hold the stripper at an angle when closing on the buffer to avoid bending the fiber sharply.

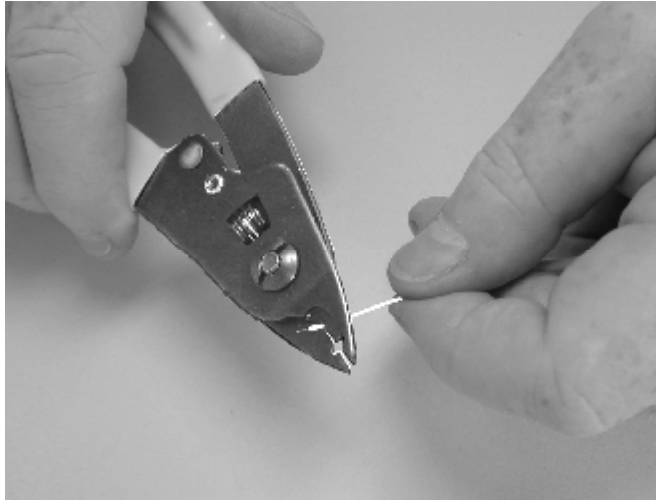

Rather than stripping the fiber completely at one time, which may break the fiber, strip in several short strips of about 1/8" (3 mm) at each time until you reach the desired finished length. This will relieve any pressure caused by the buffer as it bunches up ahead of the stripping tool.

If fouling occurs in the vee of the tool, clean with denatured alcohol or by sliding a cleaning wire through the opening of the vee jaws. Excessive fouling will sever the fiber.

Clean the vee with denatured alcohol and lightly oil the tool after use.

**Always wear safety glasses when working with bare fibers.**

## Cable Stripper For Cutting Buffer Tubes

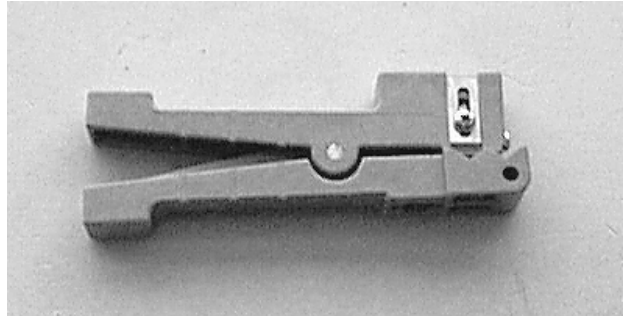

This lightweight stripper will make round or axial cuts on jacket/buffer tubes quickly and easily. The adjustable blades can be set to any depth from 1/8in. to 7/32in. (3.175mm to 5.556mm) to assure nick-free strips. Each stripper comes complete with one round and three straight blades.

### Adjusting blade height

Place the cable in the notch so it is tight against the blade. Loosen the screw and adjust the blade to the desired cut depth. Tighten the screw to lock the blade in position and repeat for the other blade. Make a test strip to double check the height of the blades. It may be necessary to “fine tune” the blade height several times.

### Stripping

After adjusting the blade heights, place the cable in the notch closest to the pivot. The spring will force the blades into the cable jacket. Let the spring do the work, since pushing the heads together may damage the blades.

For best results, the stripper must be properly positioned on the cable. The name and logo are on top and the blades point down when in the correct position (, see above picture). Rotate the tool around the cable by pushing down on the top handle (the above picture would rotate counter-clockwise). Turning in the opposite direction may cause the stripper to “walk “ off the cable. Approximately six to eight rotations will be necessary to cut the jacket. After circumscribing the cable, “snap” the cable jacket by bending sharply at the cut.

The square blade on the front of the stripper is for making axial cuts. To make this cut, place the cable in the front notch and press the head together until the blade cuts through the cable.

A round blade is included for slitting lengths of cable. Replace the square blade on the front of the stripper with the rounded blade and adjust the height. Place the cable in the front notch and pull the cable through.

## Fiber Optic Crimp Tool

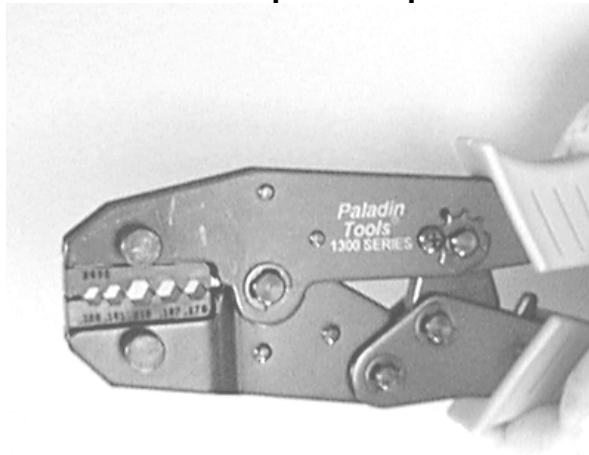

The crimp tool provides the proper compression force required to insure retention of the connector on the cable. The toggle action provides a very high mechanical advantage assuring a proper crimp each time. The ratchet feature means that once a crimping cycle is started, it must be completed, insuring a complete crimp.

### Operation

Refer to your connector instructions to choose proper size of crimp for that connector.

### Die Sizes (From the front of the die):

0.128, 0.151, 0.215, 0.197, 0.178 or 0.128, 0.151, 0.178

To start the crimping process, operate the tool through its normal cycle. When the cycle is complete, the pawl mechanism will automatically release and allow the tool to open. Position the connector and cable assembly into its proper hex cavity and begin closing the tool. Continue this crimp cycle until the lever arm has bottomed out and the toggle action is achieved. At this time, the "Full Cycle" mechanism will automatically release and the tool can be opened in order to remove the crimped connector and cable assembly.

If the ring and connector are not secure on the cable after crimping, check for undersize O.D. of the cable. Never Re-Crimp in a smaller hex die opening. This will damage the tool.

### Finished Crimp Appearance

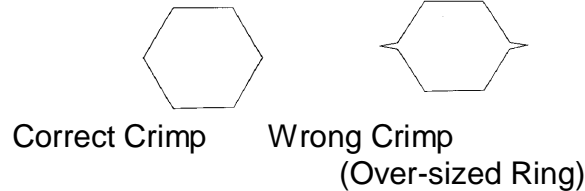

If the finished crimp looks like the one pictured above right, an over sized crimp ring was used. Completing the crimp will damage the tool. Check with the connector manufacturer for the proper crimp ring size.

### Lubrication

Proper lubrication of this tool is very important. Lack of lubrication will greatly reduce the life of the tool. A “3 in 1” oil should be applied at regular intervals to all exposed pin and pivot points, as well as the pawl and ratchet gear on the “Full Cycle Crimp Tool”.

### Compression Adjustment

To overcome normal wear and to ensure longer tool life, a compression adjustment feature has been added. After extensive use, the jaws may not close completely and provide the correct crimp. If this happens, the tool can be adjusted by removing the socket head screw from the adjustment “Star Wheel”. Move the “Star Wheel” clockwise in 1/2 to 1 indents or until proper adjustment is obtained and replace the setscrew in the threaded hole closest to the proper setting.

### Star Wheel

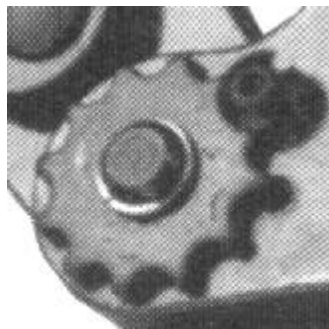

**Set Screw**

**Alternate  
Set Screw Hole**

### Changing Dies:

- 1) Remove the die by unscrewing the two knurled thumbscrews on the crimper body
- 2) The alignment pin should be on the end of the die away from the handle (0.128 end)
- 3) Close the handles gently to allow the die halves to align before tightening thumbscrews.
- 4) The lever between the handles releases the crimper ratchet before it has fully closed.

## Scribe

This is a 30-degree Sapphire scribe 3.8mm wide for long life and simple fiber termination. Housed in a rugged, anodized aluminum casing, this scribe fits comfortably in either hand. It is designed to make quality cleaves safely and quickly.

Use the scribe to cleave the excess fiber from a connector when terminating. Simply scratch the fiber as close to the ferrule as possible with the scribe and pull straight to cleave the fiber neatly.

### **When cleaving fiber be sure to wear protective eye wear and to dispose of the cleaved fiber appropriately.**

- 1) Hold the scribe at a 90-degree angle to the fiber and lightly scratch across the fiber. It is important to hold the scribe square to the fiber horizontally and vertically.
- 2) After scribing, the fiber will break along the scribe mark leaving a clean square cleave.
- 3) Dispose of the cleaved fiber and cover the scribe.
- 4) Inspect the cleave with the fiber optic inspection microscope.

## Polishing Fixture, Plate and Pad

This is a high quality, precision, polishing fixture designed to hold SC, ST, or FC style connectors. It holds these connectors in a “float” condition. It is important that the fixture remain flat on the polishing surface while in use. Do not allow it to lift while polishing.

1. Place polishing film on the glass plate. Double up two layers of film to provide a slightly softer surface.
2. Take the connector and place it into the polishing fixture. Gently lay the fixture down on the polishing film. Do not allow the fixture to drop onto the glass plate or use any force when laying it down. This may shatter the fiber.
3. Sweep the fixture across the film in a “figure 8” motion. Move the “figure 8” pattern across the film to ensure there is always fresh polishing film under the connector.

**Note:** With a ceramic connector, use almost no pressure at all on the connector when polishing. With a stainless connector, use about two to three pounds.

The rubber polishing pad provided in your toolbox is used for polishing PC finish connectors. It is of a precise hardness that will allow a domed end to the connector. Follow singlemode polishing directions when using the pad with singlemode connectors. Multimode connectors can be polished using normal instructions.

## Continuity Tester (FCT-100)



The FCT-100 is a bright visible light source for checking continuity or quickly tracing multimode fibers in networks to insure proper connections, a difficult task in large fiber count systems. In addition, it can be used as a continuity checker to determine if jumper cables with connections or fiber on reels are in good condition or if installed fiber has been damaged. With a range of 4 km (2.5 mi.), it is perfect for testing and troubleshooting every multimode fiber network. And it's so inexpensive; every installer in the crew can afford one!

Model	Fiber	Range	Power	Connectors
FCT-100	MM	4 km	1-AAA battery	ST/SC/FC

### FCT-100 Assembly



### FCT-100 Use

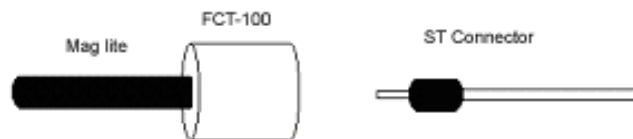

## MSP-200XP (200 power microscope)

The MSP-200XP Fiber Microscope utilizes a white LED for coaxial illumination. Light is focused into the optical path (axis) so that it comes out the tip of the ferrule and strikes the sample perpendicular to the fiber end-face. It produces excellent detail of scratches and contamination.

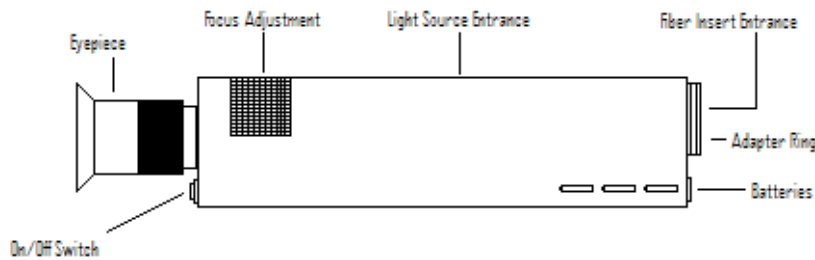

### Specifications:

**Optical Magnification:** 200x

**Power Requirements:** 3 “AAA” alkaline Batteries

**LED:** Rated life: 100,000 Hrs

**Weight:** 0.6Kg

**Size:** 225mm/8.76”L x 32mm/1.25” Diameter

**Controls:** Momentary On/Off switch, Fine-Focus control

**Safety Filter:** Built in IR filter

**Adapter Interface:** User Interchangeable – 2.5mm universal standard

### Operation Step:

**Step 1.** Input the Fiber to be inspected into the fiber insert entrance, insert another fiber connector into the light source entrance.

**Step 2.** Look through the Eyepiece and press on the On/Off LED switch (illumination).

**Step 3.** Adjust the focus control as required to find the clearest viewing.

**Laser Safety Information:** The MSP-200XP is equipped with an attenuating, laser safety filter to reduce the risk of eye damage when the user accidentally views a fiber with active emissions. It should be stressed that in spite of the protection offered, under no circumstances should an actively emitting fiber be viewed with this microscope.

**Warning:** Always make sure that the fiber being examined is not active by using a power meter first. Inspection of a fiber optic cable when it is emitting active light may cause permanent eye damage.

## Fiber Optic Portable Curing Oven

1. Advanced Fiber Solutions offers a portable curing oven that terminates 6 low cost epoxy/polish connectors in a matter of minutes.
2. The average curing time is 5 to 10 minutes at Fixed 90°C.
3. Fits most connector styles including the standard ST, FC and SC connectors.
4. Terminates low cost connectors in the same amount of time as expensive quick connectors while also producing a much higher yield.
5. Powered by either a 12V wall mount DC adaptor or a 12V DC vehicle outlet.
6. The portable curing oven block is cased in a molded rubber housing that is extremely rugged for extensive field use.
7. With 90% plus yield of inexpensive connectors the portable curing oven is the ideal tool for fast, reliable and economic termination!

### Specifications

- Number of Ports: 6
- Temperature Stability: +/- 5° c
- Temperature Range: 90° c
- Accuracy: +/- 8°c
- Power: 120VAC to 12V, 1.5 Amp (We offer 240VAC to 12V version)
- Time to 90° c = ~15 Mins
- Optional - 12V car adapter

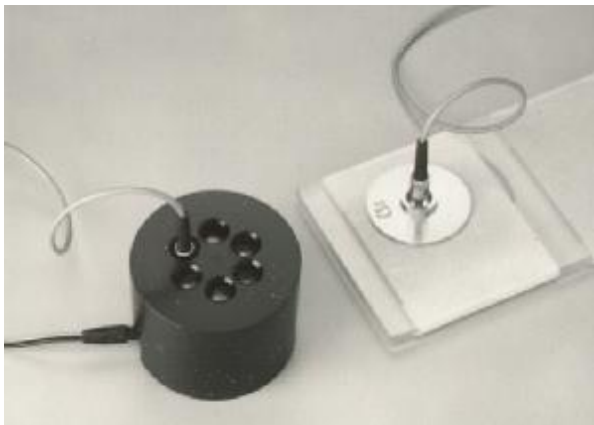

**WARNING: These units get *HOT!***